

2345P MAGNE-TRACTION POWER UNIT (WESTERN PACIFIC)

Part Number	Description	Price	Part Number	Description	Price
<u>Body Assembly</u>			<u>Front Power Truck Assembly (Cont'd)</u>		
2345-4	Body Complete	\$6.00	2333-63	Shield Screw	\$.05
2332-7	Ornamental Horn	.15	2333-60	Coupler & Drawbar Complete	1.25
2345-8	Marker Lens R.H.	.20	2333-64	Drawbar Centering Spring	.05
2345-10	Marker Lens L.H.	.20	6TC-10	Coupler & Coil Assembly	.60
2333-11	Headlight Lens	.15	TC-21	Coupler Knuckle	.10
2333-12	Wire Cloth Ventilator	.15	TC-22	Knuckle Spring	.02
2333-13	Twin Type Speed Nut	.10	TC-23	Knuckle Rivet	.02
2343-133	Side Window	.05	TC-112	Plunger Spring	.02
2333-15	Cab Door Ladder	.10	TC-113	Plunger	.05
2333-16	Grab Handle	.10	2343-33	Drive Wheel	.25
2333-25	Window Shell	.40	2343-78	Magnetized Axle	.35
167-20	Speed Nut	.05	2343-79	Axle Bushing	.05
2345-11	Decal (Western Pacific)	.05	2333-48	Worm Shaft Gear	.25
622-126	Decal (G.M.)	Pr. .05	2343-37	Worm Wheel	.50
#4x3/8"	STFHI "Z" Screw (Front)	.02	2343-40	Collector Assembly	1.50
#6x1/2"	STFHI "Z" Screw (Rear)	.02	2333-42	Collector Insulator Washer	.05
<u>Motor Assembly</u>			4-40x3/8"	RHI Screw (Collector)	.02
#2343-100	Motor Complete	6.50	*2333-34	Collector Insulator	.05
or	Substitute		or Substitute		
*2333M-1	Motor Complete	6.50	*2023-115	Collector Insulator	.05
6-32x1"	Fil. H.I. Sc. (Motor Mtg)	.02	671-112	Collector Insulator Washer	.02
2343-119	Brush Plate Assembly	.75	2343-94	Collector Arm Assembly	.40
2343-122	Nut Slotted (Brush Plate)	.05	622-145	Collector Spring R.H.	.05
622-121	Brushes	Pr. .60	622-146	Collector Spring L.H.	.05
622-118	Brush Springs	Pr. .10	2333-33	Collector Arm Pin	.05
2020M-17	Front Bearing	.10	2333-39	Collector Frame	.30
671M-20	Rear Bearing	.10	2343-95	Collector Roller	.15
2333M-8	Armature	2.25	2023-44	Roller Pin	.02
2333M-14	Drive Gear	.20	480-20	Shoe Rivet	.02
2333M-15	Idler Gear Assembly	.30	TT-208	Shoe	.05
2343-80	3 Conductor Cable	.20	TC-109	Shoe Plate	.02
<u>Front Power Truck Assembly</u>			6TC-12	Shoe Spring	.05
2343-21	Front Truck (Magnetized)	9.50	1041-55	Terminal Solder Lug	.20
2333-44	Dual Worm Shaft Assembly	1.00	<u>Rear Power Truck Assembly</u>		
2333-51	Truck Frame Cover Assembly	.25	2343-19	Rear Truck (Magnetized)	6.50
2333-53	Pivot Stud	.05	2333-72	Rear Truck Nameplate	.05
4-40x1/4"	BHI Screw (Truck Cover)	.02	4-40x1/8"	RHI Screw (Nameplate)	.02
2333-68	Truck Side (Silver)	.50	2333-75	Dummy Coupler	.25
2333-57	Ladder R.H.	.10	2333-74	Coupler Retaining Plate	.10
2333-58	Ladder L.H.	.10	2333-76	Rivet	.05
6-32x5/16"	BHI Screw (Ladder)	.02	2333-44	Dual Worm Shaft Assembly	1.00
2333-65	Worm Shaft Bearing	.10	2333-48	Worm Shaft Gear	.25
2333-54	Ball Bearing	.02	2333-51	Truck Frame Cover Assembly	.25
2333-59	Apron (Silver)	.60	2333-53	Pivot Stud	.05
4-40x5/16"	FHI Screw (Apron)	.02	4-40x1/4"	BHI Screw (Truck Cover)	.02
2333-62	Shield	.10	2333-68	Truck Side (Silver)	.50
			2333-57	Ladder R.H.	.10
			2333-58	Ladder L.H.	.10

(Continued)

2345P MAGNE-TRACTION POWER UNIT (WESTERN PACIFIC)

(Continued)

<u>Part Number</u>	<u>Description</u>	<u>Price</u>
<u>Rear Power Truck Assembly (Cont.)</u>		
6-32x5/16	BHI Screw (Ladder)	\$.02
2333-65	Worm Shaft Bearing Assy.	.10
2333-54	Ball Bearing	.02
2343-33	Drive Wheel	.25
2343-79	Axle Bushing	.05
2343-37	Worm Wheel	.50
2343-78	Magnetized Axle	.35
<u>Frame Assembly</u>		
2333-37	Frame Complete (Silver)	3.00
2333-24	Lamp Socket	.20
2333-23	Rear Ladder	.10
2333-89	Cable Clamp	.05
6-32x3/16	RHI Screw (Cable Clamp)	.02
2333-129	Battery Swivel Plate	.35
2333-115	Shoulder Rivet	.05
2333-116	Lock Screw (Swivel Plate)	.05
R-91	Spring	.05
2333-21	Lamp Lead Assembly	.15
2026-58	18 Volt Clear Lamp	.30
<u>Miscellaneous</u>		
2343-55	Horn	2.00
4-36x1/4"	RHI Screw (Horn)	.02
2333-121	Relay	2.00
2333-120	Relay Bracket	.40
2333-123	Insulation	.05
2401-19	Shoulder Fibre Washer	.05
45-58	Solder Lug	.02
6-32x5/16"	RHI Screw (Relay Bracket)	.02
6-32x1/4"	Fl. H.I. Screw (Relay)	.02
WS-69	#6 Lockwasher	.02
W-10	Cable Clamp Lug	.05
*2333-80	Reversing Unit	2.75
	or Substitute	
*100-5	Reversing Unit	2.75
45-73	#4 Lockwasher	.02
4-40x1/4"	RHI Screw (Rev. Unit)	.02

2345T MAGNE-TRACTION TENDER UNIT (WESTERN PACIFIC)

<u>Part Number</u>	<u>Description</u>	<u>Price</u>
<u>Body Assembly</u>		
2345-4	Body Complete	\$6.00
2332-7	Ornamental Horn	.15
2345-8	Marker Lens R.H.	.20
2345-10	Marker Lens L.H.	.20
2333-11	Headlight Lens	.15
2333-12	Wire Cloth Ventilator	.15
2333-13	Twin Type Speed Nut	.10
2333-167	Side Window	.05
2333-15	Cab Door Ladder	.10
2333-16	Grab Handle	.10
2333-25	Window Shell	.40
167-20	Speed Nut	.05
2345-11	Decal (Western Pacific)	.05
622-126	Decal (G.M.)	Pr. .05
#4x3/8"	STFHI "Z" Screw (Front)	.02
#6x1/2"	STFHI "Z" Screw (Rear)	.02

Front Tender Truck Assembly

2333-154	Front Tender Truck	7.00
*480-18	Retaining Washer	.02
	or Substitute	
*TS-70	Retaining Washer	.02
2333-51	Truck Frame Cover Assembly	.25
2333-53	Pivot Stud	.05
4-40x1/4"	BHI Screw (Truck Cover)	.02
2333-68	Truck Side (Silver)	.50
2333-57	Ladder R.H.	.10
2333-58	Ladder L.H.	.10
6-32x5/16"	BHI Screw (Ladder)	.02
2333-59	Apron (Silver)	.60
4-40x5/16"	FHI Screw (Apron)	.02
2333-62	Shield	.10
2333-63	Shield Screw	.05
2333-60	Coupler & Drawbar Comp.	1.25
2333-64	Drawbar Centering Spring	.05
6TC-10	Coupler & Coil Assembly	.60
TC-21	Coupler Knuckle	.10
TC-22	Knuckle Spring	.02
TC-23	Knuckle Rivet	.02
TC-112	Plunger Spring	.02
TC-113	Plunger	.05
2333-32	Drive Wheel	.25
2333-28	Axle Bushing	.05
671-25	Axle	.05
2343-40	Collector Assembly	1.50

<u>Part Number</u>	<u>Description</u>	<u>Price</u>
<u>Front Tender Truck Assembly (Cont.)</u>		
2343-	Collector Arm Assy.	\$.40
2343-	Collector Roller	.15
2023-	Roller Pin	.02
2333-42	Collector Insulator Washer	.05
4-40x3/8"	RHI Screw (Collector)	.02
671-112	Collector Insulator Washer	.02
*2333-34	Collector Insulator	.05
	or Substitute	
*2023-115	Collector Insulator	.05
622-145	Collector Spring R.H.	.05
622-146	Collector Spring L.H.	.05
2333-33	Collector Arm Pin	.05
2333-39	Collector Frame	.30
TT-208	Shoe	.05
622-68	Shoe Rivet	.02
TC-109	Shoe Plate	.02
6TC-12	Shoe Spring	.05
1041-55	Terminal Solder Lug	.02

Rear Tender Truck Assembly

2333-152	Rear Tender Truck	4.00
*480-18	Retaining Washer	.02
	or Substitute	
*TS-70	Retaining Washer	.02
2333-72	Nameplate	.05
4-40x1/8"	RHI Screw (Nameplate)	.02
2333-75	Dummy Coupler	.25
2333-74	Coupler Retaining Plate	.10
2333-76	Rivet	.05
2333-51	Truck Frame Cover Assembly	.25
4-40x1/4"	BHI Screw (Truck Cover)	.02
2333-53	Pivot Stud	.05
2333-68	Truck Side (Silver)	.50
2333-57	Ladder R.H.	.10
2333-58	Ladder L.H.	.10
6-32x5/16"	BHI Screw (Ladder)	.02
2333-28	Axle Bushing	.05
2333-32	Wheel	.25
671-25	Axle	.05

Frame Assembly

2333-73	Frame Complete (Silver)	3.00
2333-24	Lamp Socket	.20
2333-23	Rear Ladder	.10
2333-21	Lamp Lead	.15
R-91	Spring	.05
2026-58	18 Volt Clear Lamp	.30

This tender unit is called 'Magne-Traction' for identification purposes only and is not actually magnetized. It is identical with 2333 tender unit with the exception of the marker lenses and construction of the collector roller system.

LIONEL SERVICE MANUAL

NOS. 2343P, 2344P & 2345P - POWERED DIESEL LOCOMOTIVES

Part Number	Location	Unit Price	Min. Quan.	Description
6TC-10	P-61	.75		Coupler & Coil Assem.
6TC-12	P-71	.05	12	Shoe Spring (Collector)
45-58	H-95	.02	25	Solder Lug (Relay)
45-73	A-61	.02	25	#4 Lockwasher (Revers. Unit)
61-22	A-61	.05	25	Lamp Contact
100-5	C-12	3.50		Reversing Unit
167-20	J-91	.05	10	Speednut (Window Shell)
480-20	P-71	.02	50	Shoe Rivet (Collector)
622-118	B-77	pr.10	6 pr	Brush Spring
622-121	B-77	pr.60	6 pr	Motor Brush
622-126	B-77	.02	25	Decal (G. M.) (for 2345 only)
622-145	F-56	.05	12	Collector Spring RH
622-146	F-56	.05	12	Collector Spring LH
671-112	C-57	.02	25	Collector Insulation
671M-20	C-75	.15	4	Rear Bearing
1041-55		.02	25	Solder Lug (Collector)
1445-300	LC	.30	10	Lamp
2020M-17	E-84	.15	4	Front Bearing (Motor)
2023-44	F-96	.05	12	Roller Pin
2023-115	M-31	.05	12	Collector Insulator
2245-41	L-62	.30		Coupler Head
2332-7	E-87	.20		Ornamental Horn
2333-11	F-81	.15	4	Headlight Lens
2333-12	F-91	.15	4	Wire Ventilator
2333-13	F-91	.10	6	Twin Type Speednut (Ventilator)
2333-15	F-91	.10	6	Ladder (Cab Door)
2333-16	F-91	.10	6	Grab Handle (Cab)
2333-23	F-47	.15	4	Rear Ladder (Frame)
2333-24	F-47	.25		Lamp Socket
2333-25	F-47	.40		Window Shell
2333-26	F-52	.05	12	Decal (Santa Fe)
2333-34	F-52	.05	12	Collector Insulator
2333-37	B-55	4.00		Frame Assem. (For 2343)
2333-39	F-52	.30		Collector Frame
2333-44	F-62	1.50		Dual Worm Shaft Assem.
2333-48	F-62	.40		Worm Shaft Gear
2333-51	F-62	.25		Truck Frame Cover Assem.

- continued -

<u>Part Number</u>	<u>Location</u>	<u>Unit Price</u>	<u>Min. Quan.</u>	<u>Description</u>
2333-53	F-72	.05	12	Pivot Stud (Truck)
2333-54	F-72	.02	25	Ball Bearing
2333-57	F-72	.15	4	Ladder RH
2333-58	F-72	.15	4	Ladder LH
2333-59	F-72	.60		Apron (Silver)
2333-60	F-72	2.00		Coupler & Drawbar Assem.
2333-62	F-82	.10	6	Shield (Truck)
2333-63	M-57	.05	12	Shield Screw
2333-64	F-82	.05	12	Drawbar Centering Spring
2333-65	F-82	.15	4	Worm Shaft Bearing
2333-68	F-82	.75		Truck Side (Silver)
2333-72	F-92	.05	12	Nameplate (Rear Truck)
2333-74	F-92	.10	6	Coupler Retaining Plate
2333-75	Sub. 2245-41			Dummy Coupler
2333-76	F-92	.05	12	Rivet (Coupler Plate)
2333-89	F-92	.05	12	Cable Clamp
2333-104	F-92	.05	12	Decal (G.M.)
2333-115	F-57	.10	6	Shoulder Rivet (Battery Plate)
2333-116	F-57	.10	6	Lock Screw (Battery Plate)
2333-120	F-53	.60		Relay Bracket
2333-121	F-53	3.00		Relay Complete
2333-123	F-53	.05	12	Relay Insulation
2333-129	Sub. 2367-34			Battery Swivel Plate
2333-168	Obsolete			Collector Arm Pin
2333M-1	Sub. 2343-100			Motor Complete
2333M-8	A-25	3.00		Armature
2333M-14	F-73	.25		Drive Gear
2333M-15	Obsolete			Idler Gear Assem.
2334-4	G-35	7.00		Cab Assem. "N.Y. Central"
2334-8	B-65	4.50		Frame Assem.
2334-10	F-83	.50		Truck Side (Gray)
2334-13	F-83	.60		Apron (Gray)
2334-15	F-93	.02	25	Decal (N.Y. Central)
2334-23	F-93	.05	12	Decal G.M. (For 2344 Only)
2343-8	F-87	.25		Marker Lens RH
2343-10	F-87	.25		Marker Lens LH
2343-19	L-14	6.50		Rear Truck (Magnet.)

- continued -

LIONEL SERVICE MANUAL

NOS. 2343P, 2344P & 2345P - POWERED DIESEL LOCOMOTIVES PAGE 3

Part Number	Location	Unit Price	Min. Quan.	Description
2343-21	B-41	9.50		Front Truck (Magnet.)
2343-33	L-17	.30		Drive Wheel
2343-37	F-77	.75		Worm Gear
2343-40	Q-68	2.00		Collector Assem.
2343-55	L-33	2.50		Horn Complete
2343-78	Sub. 2353-29			Axle (Magnet.)
2343-79	F-87	.10	6	Axle Bushing
2343-80	F-77	.25		3-Conductor Cable
2343-94	A-51	.40		Collector Arm W/Roller
2343-95	A-21	.20		Collector Roller
2343-100	I-15	7.50		Motor Complete
2343-119	A-55	1.50		Brushplate
2343-122	F-87	.05	12	Slotted Nut (Brushplate)
2343-133	Sub. 2353-11			Side Window
2344-8	F-76	.25		Marker Lens RH
2344-10	F-76	.25		Marker Lens LH
2344-21	D-26	9.50		Front Truck (Magnet.)(for 2344 only)
2344-26	L-16	4.00		Rear Truck (Magnet.)(for 2344 only)
2345-4	Sub. 2355-4			Cab "Western Pacific"
2345-11	G-106	.05		Decal (Western Pacific)
2353-4	Sub. 2383-2			Cab Assem. "Santa Fe" (for 2343)
2367-34	O-66	.35		Battery Swivel Plate
2383-2	F-44	7.00		Cab Assem. "Western Pacific"
2409-19	L-91	.05	12	Shoulder Washer (Relay)
R-91	N-55	.05	12	Lamp Spring
TC-21	P-71	.15	4	Coupler Knuckle
TC-22	P-93	.02	25	Knuckle Spring
TC-23	P-61	.02	25	Knuckle Rivet
TC-109	P-63	.02	25	Shoe Plate (Collector)
TC-112	P-63	.02	25	Plunger Spring
TC-113	P-73	.10	6	Coupler Plunger
TT-208	P-93	.15	4	Shoe (Collector)
W-10	O-72	.05	12	Cable Clamp Lug
WS-69	G-62	.02	25	#6 Lockwasher (Relay)
4 x 3/8"		.02	25	FHST "Z" Cab Screw (Front)
4-36 x 1/4"		.02	25	RH Horn Mtg. Screw
4-40 x 1/8"		.02	25	RH Nameplate Screw
4-40 x 1/4"		.02	25	BH Truck Cover Screw

- continued -

LIONEL SERVICE MANUAL

NOS. 2343P, 2344P & 2345P - POWERED DIESEL LOCOMOTIVES

<u>Part</u> <u>Number</u>	<u>Location</u>	<u>Unit</u> <u>Price</u>	<u>Min.</u> <u>Quan.</u>	<u>Description</u>
4-40 x 1/4"		.02	25	RH Revers. Unit Screw
4-40 x 5/16"		.02	25	FH Apron Screw
4-40 x 3/8"		.02	25	RH Collector Screw
6 x 1/2"		.02	25	FHST "Z" Cab Screw (Rear)
6-32 x 3/16"		.02	25	RH Cable Clamp Screw
6-32 x 1/4"		.02	25	Fil. H. Relay Screw
6-32 x 5/16		.02	25	BH Ladder Screw
6-32 x 5/16"		.02	25	RH Relay Bracket Screw
6-32 x 1"		.02	25	Fil. H. Motor Mtg. Screw

2343 SF 2344 NYC 2345 WP 2353 SF 2354 NYC 2356 Southern TWIN DIESEL F-3 LOCOMOTIVE

When checking the performance of the twin diesel locomotive, make sure that both motors operate equally well. Raise the locomotive on blocks and apply voltage gradually. After the locomotive had been 'run in' for about 10 or 15 minutes the starting voltage of the two motors should not vary more than one volt. If the variation is greater than that, clean the commutator and check the brushes and the tension of the brush springs of the slow motor. Occasionally, poor operation of the motor may be due to mechanical interference between the field and the armature caused by loose riveting of the field laminations. The condition is easily repaired by tightening the riveting of the field studs at point 'A,' Figure 1, with a riveting punch or a ball peen hammer.

If one motor does not operate, the locomotive wheels will skid and lose traction. Failure of a motor may sometimes be caused by the field winding coming into contact with one of the brush leads at point 'B.' If the motor operates but fails to turn the wheels examine the driving gear on the armature shaft to see that it is tightly staked to the shaft. If it has become loose, remove the gear, score the end of the shaft with giant nippers, cold chisel, etc., and force the gear back onto the shaft.

WIRING DIAGRAM OF F-3 LOCOMOTIVES

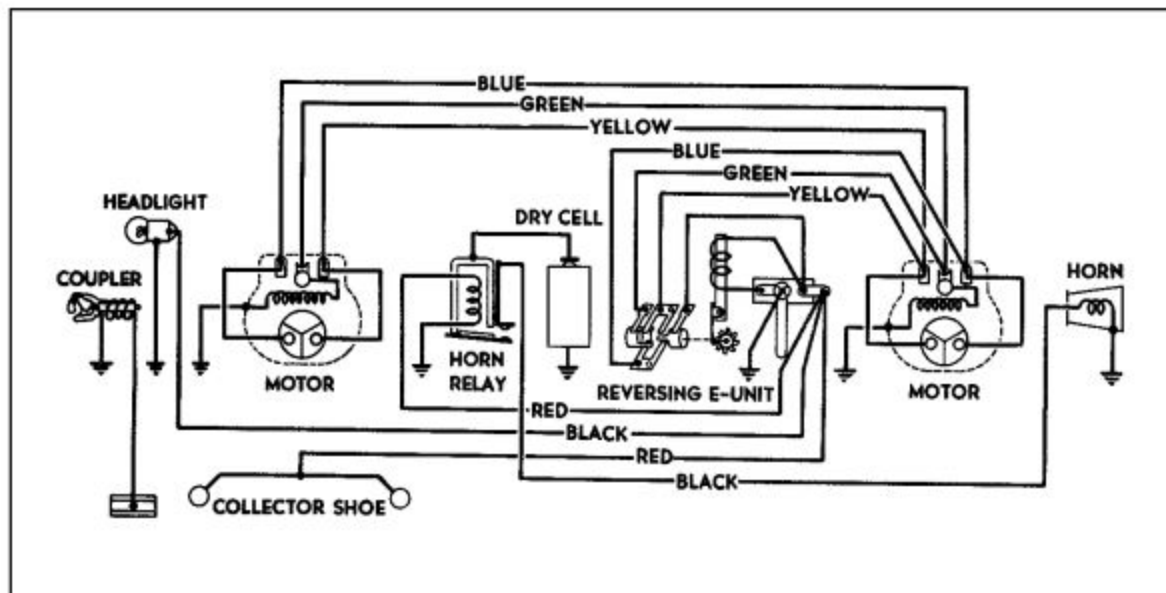

PRINTED IN U. S. OF AMERICA

TWIN DIESEL F-3 LOCOMOTIVE

COUPLER & DRAWBAR COMPLETE
2333-60
\$1.25

SHIELD
2333-62
\$.10

SHOULDER SCREW
2333-63
\$.05

FLATHEAD SCREW
4-40 x 5-16"
\$.02

APRON
(N.Y.C.) 2334-13
(SANTA FE) 2333-59
\$.60

Method for assembling Drawbar & Coupler to Apron. The Shield is assembled last. For Coupler parts see Sec. MIS-TRUCKS, P. 1

PIVOT STUD
2333-53
\$.05

BINDING HEAD SCREW
4-40 x 1-4"
\$.02

TRUCK FRAME COVER
2333-51
\$.25

BINDING HEAD SCREW
6-32 x 5-16"
\$.02

LADDER
L.H. 2333-58
R.H. 2333-57
\$.10

FRONT POWER TRUCK
2343-21
MAG TRUCK

TRUCK SIDE
(SANTA FE) 2333-68
(N.Y.C.) 2334-10
\$.50

WORM SHAFT GEAR
2333-48
\$.25

WORM SHAFT ASSY.
2333-44
\$1.00

WORM SHAFT BEARING
2333-65
\$.10

AXLE BUSHING
2343-79

MAG AXLE
2343-78

BALL BEARING
2333-54
\$.02

DRIVE WHEEL
2343-33

WORM WHEEL SUB
2343-37 2328-82

COLLECTOR ARM ASSY.
2343-94

COLLECTOR SPRING
L.H. 622-146
R.H. 622-145
\$.05

COLLECTOR PIN
2333-33

COLLECTOR INSULATOR
2023-115

COLLECTOR ASSY.
2343-40

INSULATING SPACER
671-112
\$.02

ROLLER
2343-95
PIN
2023-44

INSULATING WASHER
2333-42
\$.05

ROUND HEAD SCREW
4-40 x 3-8"
\$.02

TERMINAL SOLDER LUG
1041-55
\$.02

SHOE SPRING
6TC-12
\$.05

COLLECTOR FRAME
2333-39
\$.30

SHOE PLATE
TC-109
\$.02

SHOE
TT-208
\$.03

SHOE RIVET
622-68
\$.02

Collector Assembly 622-134 does not include the wire leads from the sliding shoe and from the terminal solder lug. The Collector Assembly on the Front Power Truck uses a 5" black coupler lead and a 7" red power lead.

TWIN DIESEL F-3 LOCOMOTIVE

PICTORIAL WIRING DIAGRAM OF F-3 LOCOMOTIVE

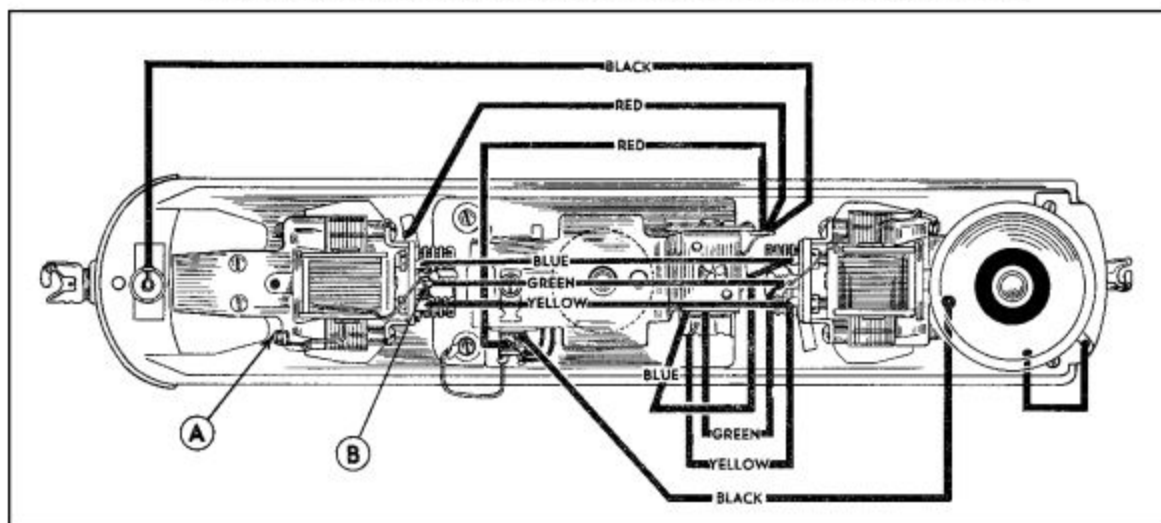

MARKER LENS

- | | |
|--------------|--------------|
| 2343-10 L.H. | 2353-6 R.H. |
| 2343-6 R.H. | 2354-10 L.H. |
| 2344-10 L.H. | 2354-6 R.H. |
| 2344-6 R.H. | 2355-10 L.H. |
| 2345-10 L.H. | 2355-6 R.H. |
| 2345-6 R.H. | 2356-10 L.H. |
| 2353-10 L.H. | 2356-6 R.H. |



HORN

2332-7
\$ 15



SIDE WINDOW

2343-133



All plastic trimmings are cemented in place by applying a thin film of Duco Household Cement to the inside edges of the openings. Side Windows 2333-14 are slightly oversize and are normally forced into place with a special shaped punch and die. Otherwise, the Side Window must be filed down to fit and then cemented into the frame.

CAB TRIMMED (SANTA FE)

2333-4
\$6.00



DECAL (G.M.)
2333-104
\$.05 pr.

HEADLIGHT LENS

2333-11
\$.15



GRAB HANDLE

2333-16
\$.10



CAB DOOR LADDER

2333-15
\$.10



WINDOW SHELL

2333-25
\$.40



SPEED NUT
167-20
\$.05



WIRE CLOTH VENTILATOR

2333-12
\$.15



TWIN SPEED NUT
2333-13
\$.10



DECAL (SANTA FE)
2333-26
\$.05



TWIN DIESEL F-3 LOCOMOTIVE

DECAL (N.Y.C.)
2334-15
\$0.05

DECAL (G.M.)
2334-23
\$.05 pr.

CAB TRIMMED (N.Y.C.)
2334-4
\$6.00

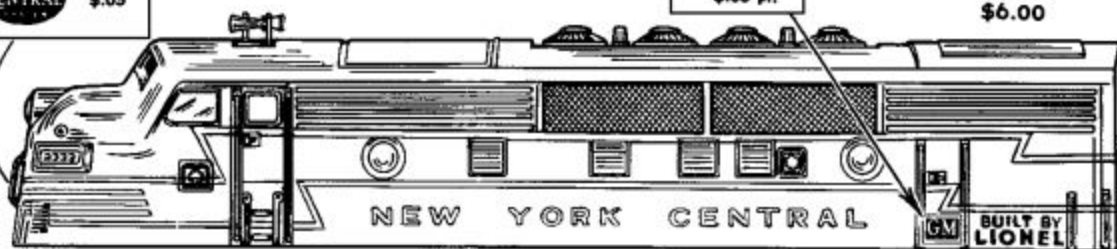

RELAY
2333-121
\$2.50

ROUND HEAD SCREW
6-32 x 5-16"
\$.02

SOLDER LUG
45-58
\$.02

SHOULDER FIBRE WASHER
2401-19
\$.05

FILLISTER HEAD SCREW
6-32 x 1-4"
\$.02

LOCKWASHER
WS-69
\$.02

SOLDER LUG
W-10
\$.05

The pitch and intensity of the horn sound are controlled by the setting of the adjusting screw on the bottom of the horn. Loosen the lock nut, adjust the screw for best sound using a 1.5 volt flashlight dry cell for power, then tighten the lock nut. The adjusting screw and the lock nut are #4-36 thread.

RELAY BRACKET
2333-120
\$.40

HORN COMPLETE
2343-55

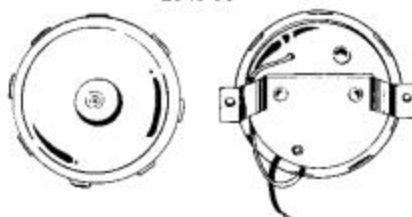

16 VOLT LAMP
1445-300

INSULATION
2333-123
\$.05

LAMP LEAD
2333-21
\$.15

SPRING
R-91
\$.05

ROUND HEAD SCREW
6-32 x 3-16"
\$.02

CABLE CLAMP
2333-89
\$.05

RELAY

ROUND HEAD SCREW
4-40 x 1-4"
\$.02

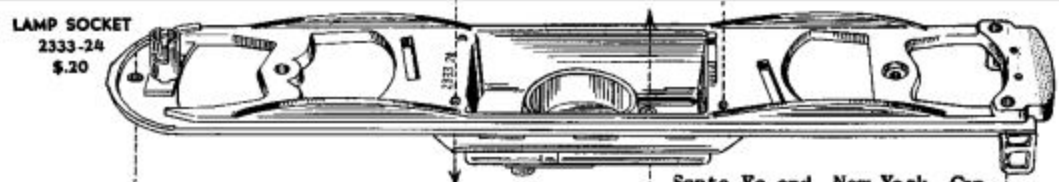

LAMP SOCKET
2333-24
\$.20

SELF-TAPPING TYPE "Z" FLATHEAD SCREW
4 x 3-8"
\$.02

SWIVEL PLATE
2367-37

Santa Fe and New York Central Frames differ from each other in color. Tender Frame assemblies are equipped with fixed plugs instead of swivel plates and lock screws.

REAR LADDER
2333-23
\$.10

FRAME ASSEMBLY

- SANTA FE POWER 2333-37
- SANTA FE TENDER 2333-73
- N.Y.C. POWER 2334-8
- N.Y.C. TENDER 2334-11

LOCK SCREW
2333-116
\$.05

SHOULDER RIVET
2333-115
\$.05

SELF-TAPPING TYPE "Z" FLATHEAD SCREW
6 x 1-2"
\$.02

\$3.00

TWIN DIESEL F-3 LOCOMOTIVE

REAR POWER TRUCK

2334-19

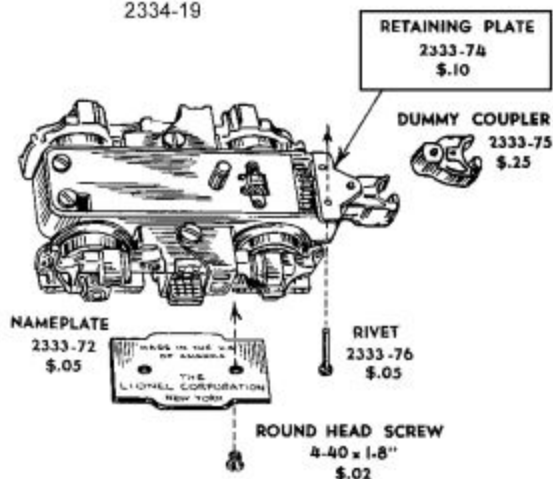

The Front and Rear Tender Trucks, illustrated on bottom of page 4, are similar to their power counterparts except that they do not have worm shaft assemblies, bearings, or worm wheels. In factory production Tender Trucks use a smooth 671-21 Axle, but Knurled Axle 671-25 can be used for replacement. Although the Front Tender Truck includes Spring R-91, Washer & Eyelet 61-22 and the lamp and coupler leads as shown, the Collector Assembly 622-134 which is used for this truck is sold unwired.

MOTOR COMPLETE

2343-100

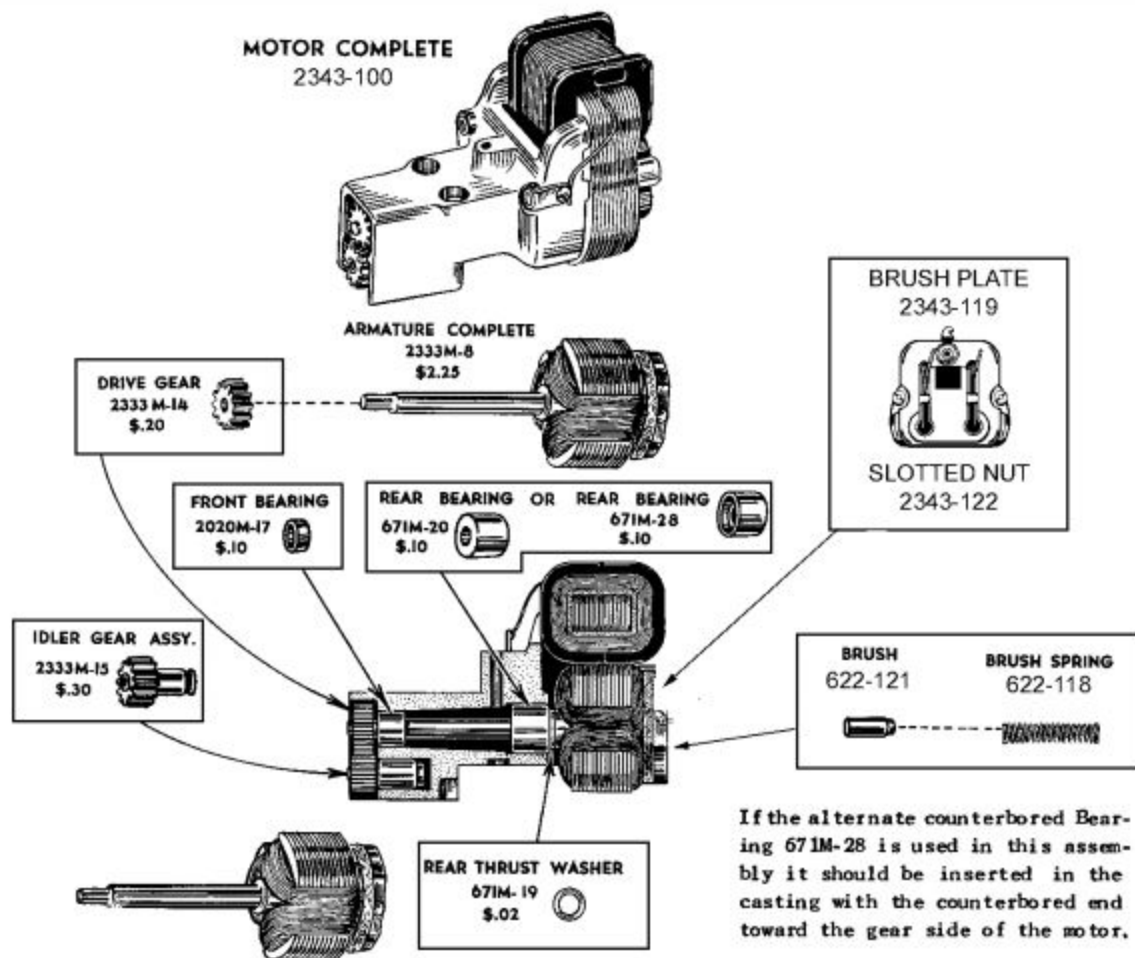

If the alternate counterbored Bearing 671M-28 is used in this assembly it should be inserted in the casting with the counterbored end toward the gear side of the motor.

TWIN DIESEL F-3 LOCOMOTIVE

